

TECHNICAL SHEET



Description	Dimension	Weight	Code
DA 1001	965,5x393x705 mm	70 kg	7041101

DA 1001 dehumidifier shall be combined with radiant cooling, and it is suitable for medium-sized commercial applications and medium occupant density spaces. Operations: air dehumidification, air recirculation, and ability to handle sensible load in the summer and winter. The unit housing is made of galvanised sheet metal, and it contains finned coils for the air handling, the refrigerant circuit for the dehumidification, the air intake filter, the condensate collection vessel, the high-efficiency supply fan and the wiring box. The unit is equipped with a display to show and set the different parameters.

- Nominal air flow rate: 1000 m³/h
- Available pressure: 375 Pa
- Dehumidification capacity: 127,5 l/24h (26 °C RH 65% water temperature 15 °C)
- Pre-treatment + condensing water flow rate at 15 °C: 1130 l/h
- Additional sensible cooling capacity up to 3994 W with supply water at 15 °C (26 °C RH 65%)
- Maximum power consumption: 2040 W
- nr. 1 syphon mandatory

COMPONENTS

AIR FLOWS



Recirculation Air



Supply Air

AIR FILTERS

Classes, Minimum Efficiency, Type Of Particulate



e(PM10) min ≤50 %
Hairs



Hydraulic connection



Ø 20 mm Condensation Drain



Wiring box

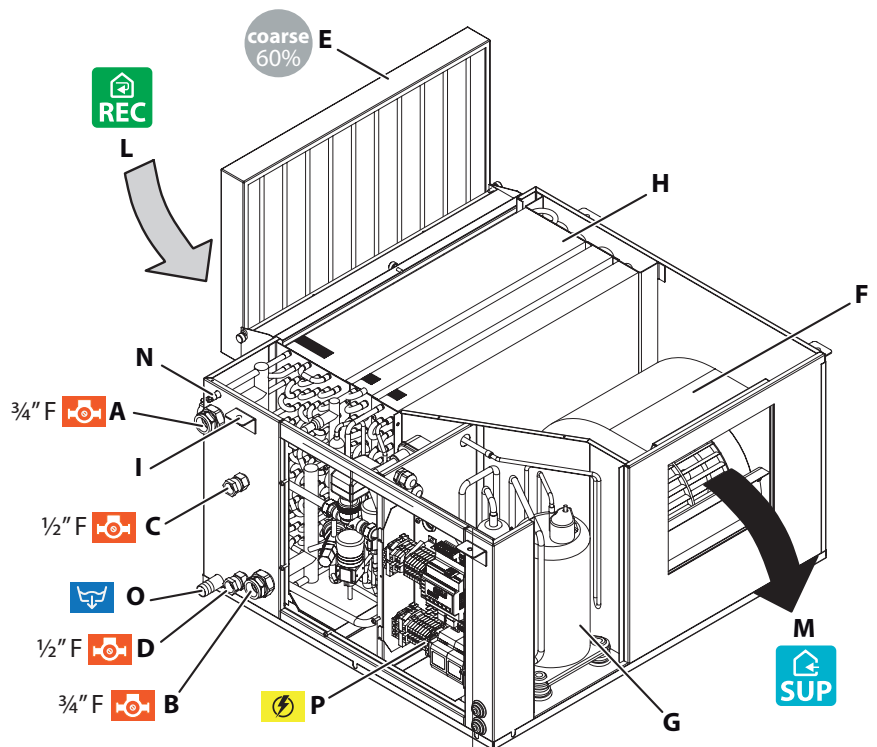

Rif.	Description	Rif.	Description
A	Pre-treatment water outlet (3/4" F)	L	Inlet air
B	Pre-treatment water inlet (3/4" F)	M	Dehumidified air outlet
C	Condenser water outlet (1/2" F)	N	Vent
D	Condenser water inlet (1/2" F)	O	Ø 20 mm condensation drain
E	Filter	P	Wiring box
F	Fan		
G	Compressor		
H	Finned pack		
I	Fixing brackets (8 mm hole)		

TECHNICAL SHEET

DIMENSIONS AND TECHNICAL DATA

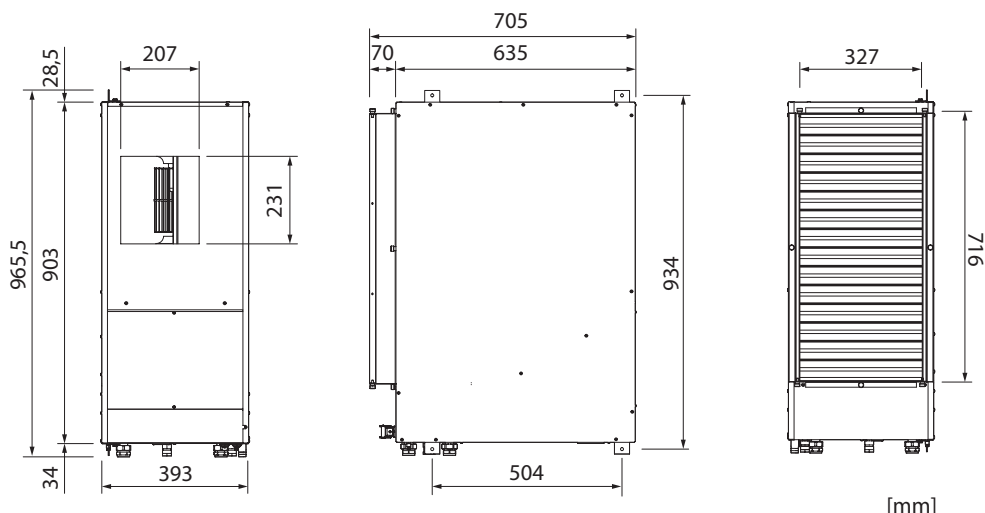

Overall unit dimensions	
Height	393 mm
Width (without hydraulic connection)	903 mm
Depth	705 mm
Weight	70 kg
Unit package	
Height	455 mm
Width	1055 mm
Depth	765 mm

Technical characteristics

Technical specifications

Condensation (26° - 65%)	l/day	127,5
Standard voltage	A	9,2
Max electrical power absorbed by the compressor	W	1040
Max electrical power absorbed by the fan	W	1000
Total max. power consumption of the fan	A	2,9
Nominal air flow rate	m ³ /h	1000
Available head	Pa	375
- Only DA		286
- DA + SR		
Pre-cooling water flow rate	l/h	1000
Pre-cooling water outlets		3/4" F
Condensation water flow rate	l/h	130
Condensation water outlets		1/2" F
Pre-cooling water head loss	kPa	23,2
- Only DA		29,4
- DA + Modulating Valve		
Refrigerant (R410A) - GWP: 2088	gr	1250
Carbon dioxide equivalent	t	2,61
Maximum operating pressure	Bar	39

MANDATORY COMPLEMENTS

The installation of no. 1 Condensate drain choosing, according to the needs, among those proposed.

Condensate drain		Code
	SF-M 20 Condensate drain kit consisting of a siphon with silicone membrane, hose and fitting, to be used in combination with RDZ air handling units.	3600400
	SF-P N Condensate drain kit with casing, designed for wall installation. It can be used in combination with RDZ air handling units, and it is suitable for Ø 20-32 mm piping. The external shell can be adjusted considering the thickness of the wall. Washable internal cartridge.	7045504

ACCESSORIES

Hydraulic		Code
	MP 5-42 Ø1" Flow Meter - Kv 9,7	7045558
	VALVOLA MODULANTE Ø 3/4" 3-way valve with 0-10V modulating servomotor, power supply 24V, Kvs 4,0	7041180

TECHNICAL SHEET

SPARE PARTS

Filters air kit		Code
	DA 1001 FILTER KIT Kit for complete replacement of unit filters containing: • 1 ISO Coarse 60% filter - Size 713x346x50 mm	7044180

OPERATING LIMIT

Summer operation: the maximum water temperature allowed in summer operation is **18 °C**. Above 19 °C, the compressor is excluded, leaving only the fan running.

Winter operation: water temperature allowed in winter operation **<55 °C**. At higher temperatures, the appliance may be damaged.

SUMMER PERFORMANCE

Performance in dehumidification mode, according to the temperature, relative humidity and temperature of the chilled water.

Only DA 1001 - Performance in dehumidification/integration mode										
Inlet air		Outlet air		Latent cooling power		Minimum inflow air temp. °C	Sensible cooling power		Cooling power to be supplied to the unit	
°C	% UR	°C	% UR	W	l/g		Max	Set 17 °C	Dehumidific.	Integration
26	55	26	42,5	2262	78,1	14,6	3994	3150	4122	8116
26	65	26	44,8	3692	127,5	15,4	3714	3150	5552	9266

DA +SR 1001 - Performance in dehumidification/integration mode										
Inlet air		Outlet air		Latent cooling power		Minimum inflow air temp. °C	Sensible cooling power		Cooling power to be supplied to the unit	
°C	% UR	°C	% UR	W	l/g		Max	Set 17 °C	Dehumidific.	Integration
33	50	26	47,9	5041	174,1	16,4	3353	3150	8156	11509
35	50	26	50,4	6268	216,4	17,2	3077	3150	9663	12739

WINTER PERFORMANCE

Maximum sensible heating capacity according to the temperature difference between inflow air into the unit and water.

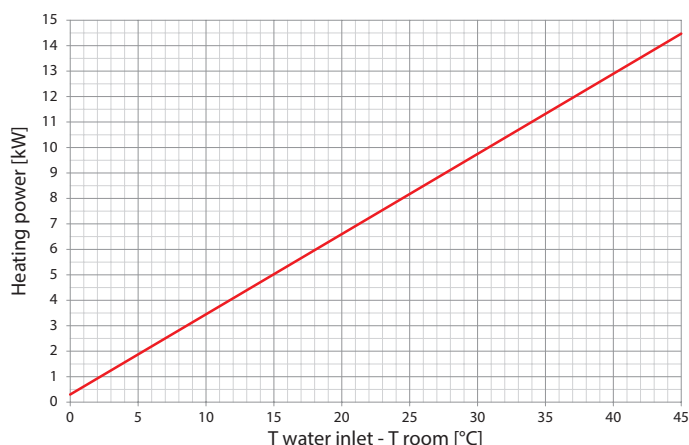

HEAT RECOVERY SR PRESSURES DROP

Pressure drop value in SR units, which should be subtracted from the aerualic performance of the DA units in case of combination into UC units.

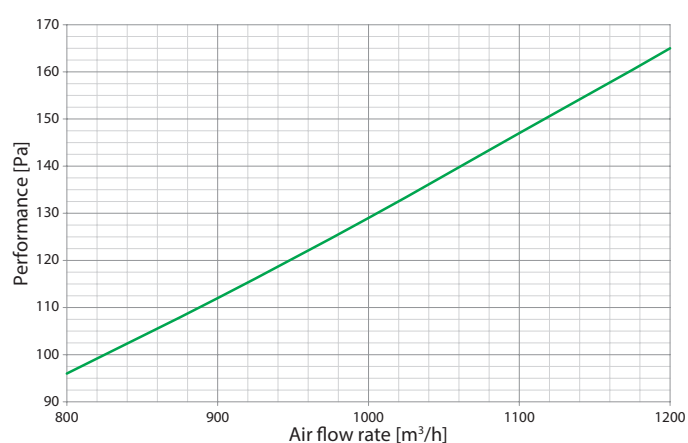

TECHNICAL SHEET

PRESSURE LOSS OF THE HYDRAULIC CIRCUIT

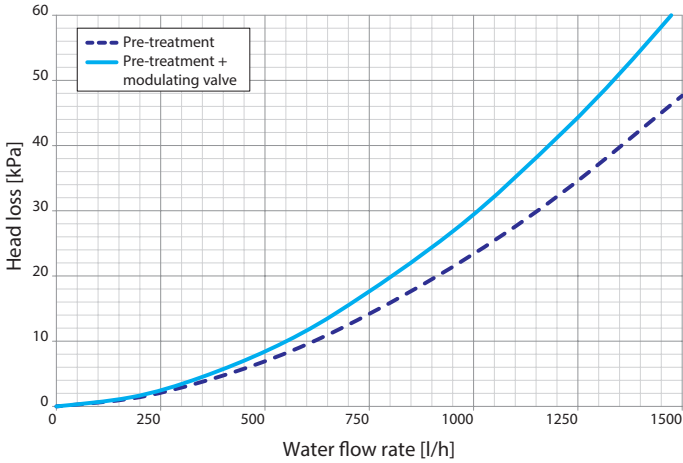

AVAILABLE PRESSURES TO THE INTAKE OUTLET

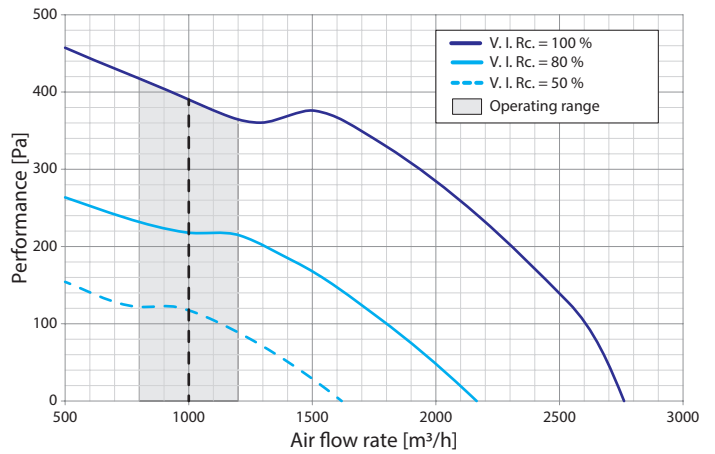

V. I. Rc.: recirculation air inlet speed

ACOUSTIC CHARACTERISTICS

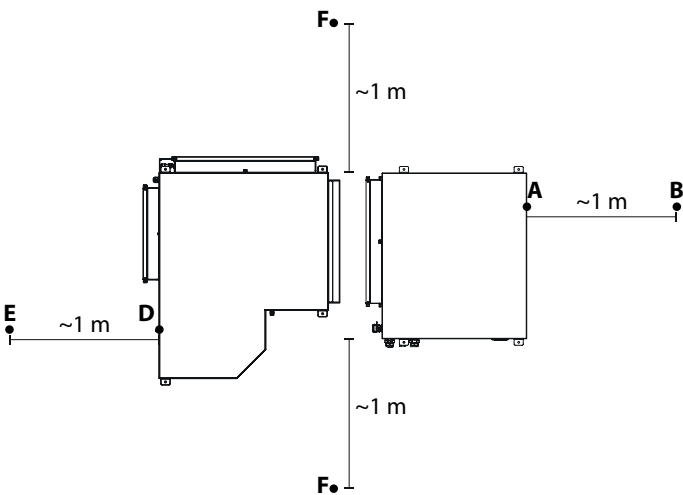

Sound pressure detected							
Operation	Speed [%]	A	B	C	D	E	F
		[db(A)]					
Air recirculation	40	81	65	54	-	-	-
Dehumidification	40	82	65	56	-	-	-
Dehumidification	30	80	61	55	-	-	-
Dehumidification	100	84	71,5	60	-	-	-
Ventilation	40	-	60	-	78	62	57
Ventilation	30	78	63	-	80	61	-
Bottom 35 db(A)							

The detected acoustic value can be further improved thanks to the noise reduction offered by the presence of the plasterboard ceiling where the machine is installed.

! It is highly recommended to install a silencer near the unit, especially near the supply line.

POSITIONING AT THE CEILING

